

VMX100LP

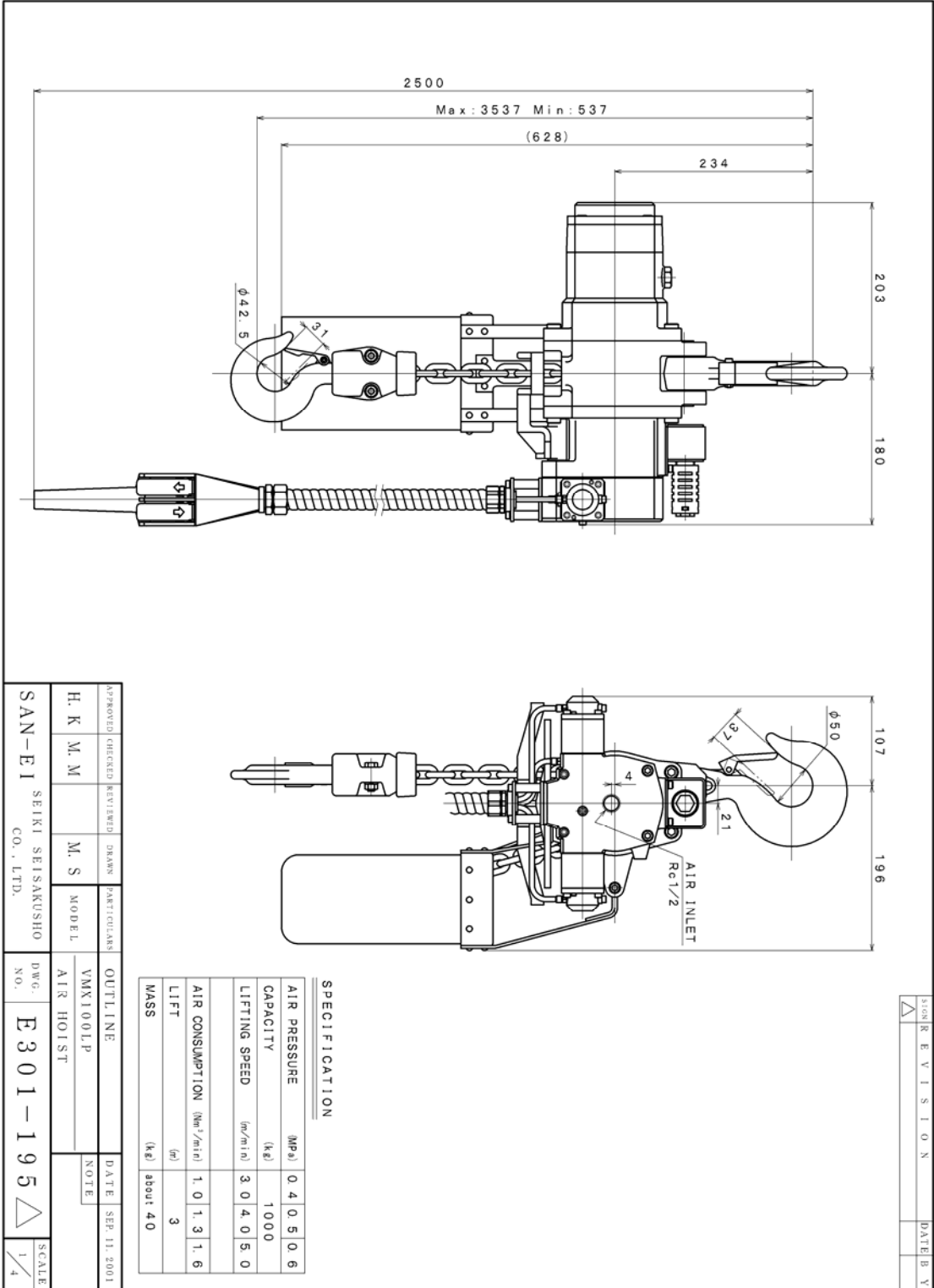

REVISION	DATE	BY

SPECIFICATION

AIR PRESSURE	(MPa)	0.4 0.5 0.6
CAPACITY	(kg)	1000
LIFTING SPEED	(m/min)	3.0 4.0 5.0
AIR CONSUMPTION	(Nm ³ /min)	1.0 1.3 1.6
LIFT	(m)	3
MASS	(kg)	about 40

APPROVED	CHECKED	REVIEWED	DRAWN	PART/COLLARS	DATE	SEP. 11. 2001
H. K. M. M.			M. S.	MODEL	VMX100LP	NOTE
SAN-EI SEIKI SEISAKUSHO CO., LTD.				AIR HOIST		
DWG. NO. E301-195					SCALE	1/4

VMX100LP-PR

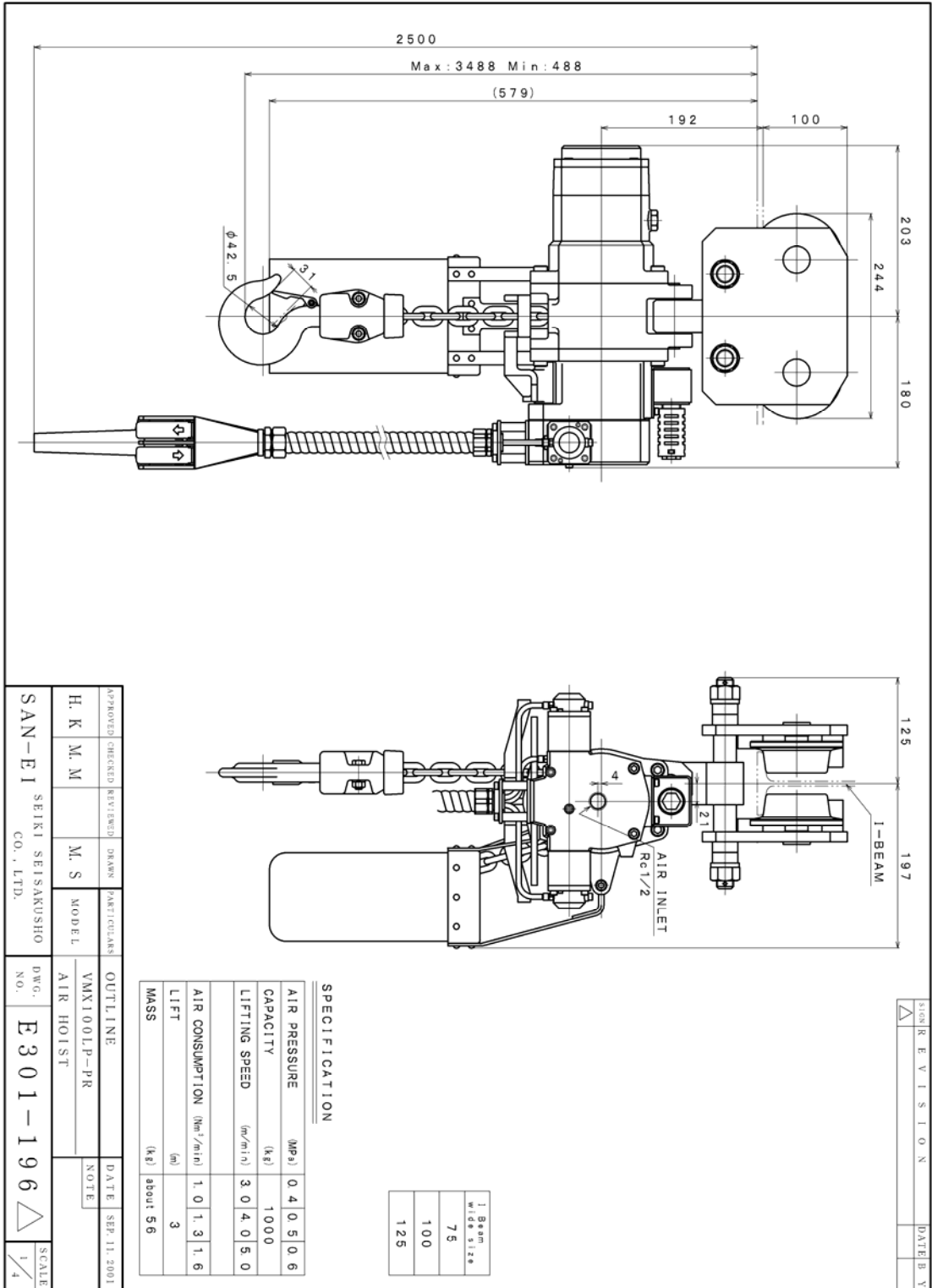

VMX100LP-GR

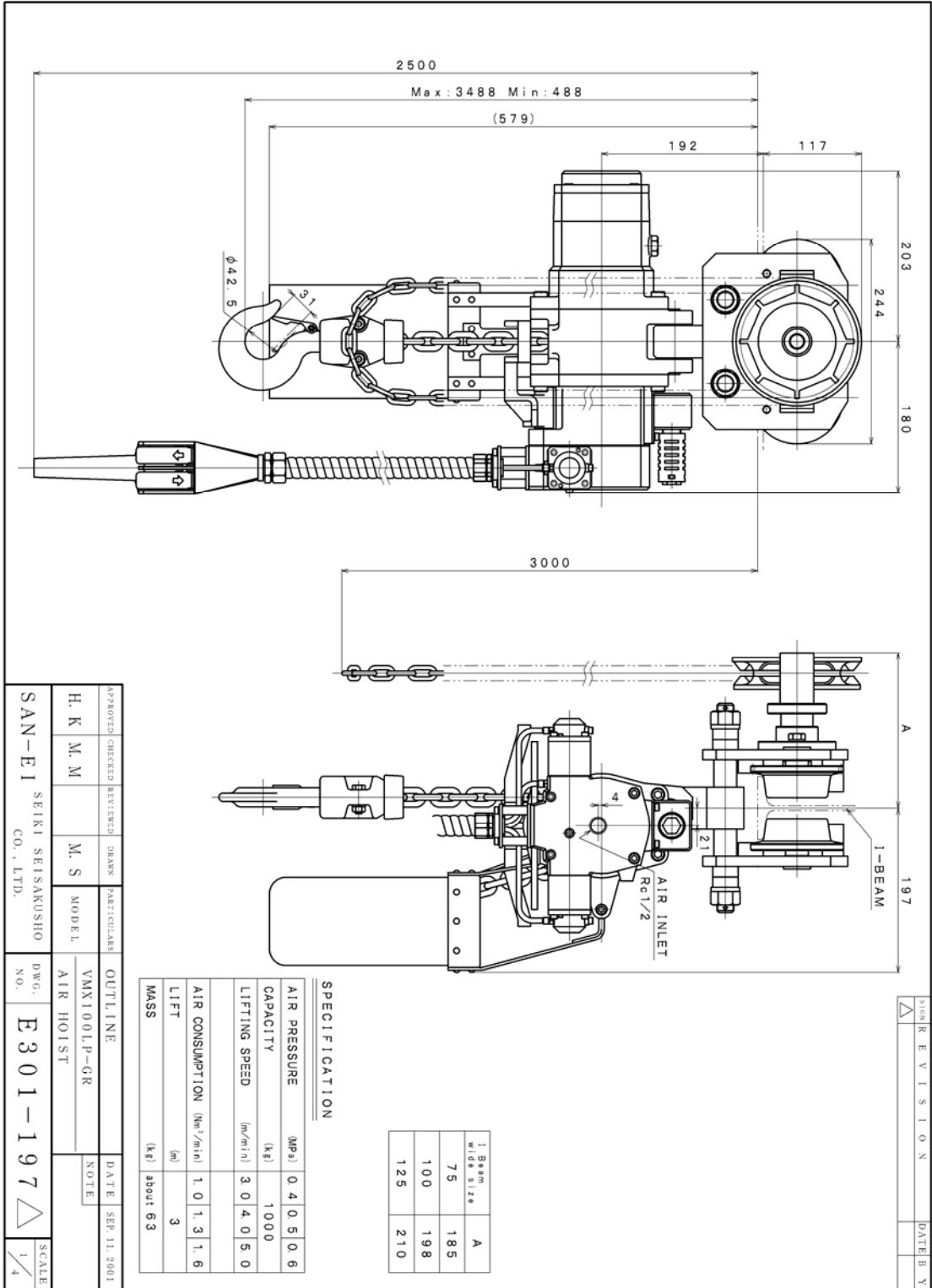

VMX100LP-MR

